

**Ranges and Resolution**

See table below. Resolution is fixed as indicated in table.

**Accuracy**

Accuracy includes linearity, hysteresis, repeatability  
 Standard accuracy: ±0.25% of full scale ±1 least significant digit  
 HA accuracy option: ±0.1% FS ±1 LSD, see ranges for availability  
 Sensor hysteresis: ±0.015% FS, included in accuracy  
 Sensor repeatability: ±0.01% FS, included in accuracy

‡ -HA option not available. Consult factory for special units.

PSI	Res	inHg/PSI	Res	mmH <sub>2</sub> O	Res
3PSIG‡	.001	-30V15PSIG‡	.1	2100MMH2O‡	1
5PSIG‡	.001	-30V100PSIG‡	.1	3500MMH2O‡	1
15PSIA	.01	-30V200PSIG‡	.1	cmH <sub>2</sub> O	Res
15PSIVAC‡	.01	inH <sub>2</sub> O	Res	2100CMH2O‡	.1
±15PSIG‡	.01	85INH2O‡	.01	3500CMH2O‡	.1
15PSIG	.01	140INH2O‡	.1	1000CMH2O A	1
30PSIA	.01	400INH2O A	.1	1000CMH2OVAC‡	1
30PSIG	.01	400INH2OVAC‡	.1	±1000CMH2O‡	1
60PSIG	.01	±400INH2O‡	1	1000CMH2O	1
100PSIA	.1	400INH2O G	.1	2100CMH2O A	1
-15V100PSIG‡	.1	850INH2O A	1	2100CMH2O G	1
100PSIG	.1	850INH2O G	1	kPa	Res
-15V200PSIG‡	.1	ftH <sub>2</sub> O	Res	20KPAG‡	.01
200PSIG	.1	7FTH2O‡	.001	35KPAG‡	.1
300PSIG	.1	12FTH2O‡	.01	100KPAA	.1
500PSIG	.1	35FTH2O	.1	100KPAVAC‡	.1
1000PSIG	1	70FTH2O	.1	±100KPAG‡	.1
2000PSIG	1	140FTH2O	.1	100KPAG	.1
3000PSIG	1	230FTH2O	.1	200KPAA	.1
5000PSIG	1	480FTH2O	.1	200KPAG	.1
oz/in <sup>2</sup>	Res	700FTH2O	.1	400KPAG	.1
50ZING‡	.01	1150FTH2O	1	700KPAA	.1
80ZING‡	.1	2300FTH2O	1	700KPAG	.1
240ZINA	.1	4600FTH2O	1	-100V700KPAG‡	1
240ZINVAC‡	.1	6900FTH2O	1	1400KPAG	1
±240ZING‡	.1	mmHg	Res	-100V1400KPAG‡	1
240ZING	.1	150MMHGG‡	.1	2000KPAG	1
480ZINA	.1	260MMHGG‡	.1	3500KPAG	1
480ZING	.1	760MMHGA	.1	7000KPAG	1
inHg	Res	760MMHGVAC‡	.1	MPa	Res
6INHGG‡	.001	±760MMHGG‡	1	1.4MPAG	.001
10INHGG‡	.01	760MMHGG	.1	-0.1V1.4MPAG‡	.001
30INHGA	.01	1600MMHGA	1	2MPAG	.001
30INHGVAC‡	.01	1600MMHGG	1	3.5MPAG	.001
±30INHGG‡	.01	Torr	Res	7MPAG	.001
30INHGG	.01	760TORRA	.1	14MPAG	.01
60INHGA	.01	760TORRVAC‡	.1	20MPAG	.01
60INHGG	.01	1600TORRA	1	35MPAG	.01
120INHGG	.1	mbar	Res	g/cm <sup>2</sup>	Res
200INHGA	.1	200MBARG‡	.1	200GCMG‡	.1
-30V200INHGG‡	.1	350MBARG‡	.1	350GCMG‡	.1
200INHGG	.1	1000MBARA	1	1000GCM A	1
-30V400INHGG‡	.1	1000MBARVAC‡	1	1000GCMVAC‡	1
400INHGG	.1	±1000MBARG‡	1	±1000GCMG‡	1
600INHGG	.1	1000MBARG	1	1000GCMG	1
1000INHGG	1	2000MBARA	1	2100GCM A	1
2000INHGG	1	2000MBARG	1	2100GCMG	1
4000INHGG	1	bar	Res	kg/cm <sup>2</sup>	Res
atm	Res	1BARA	.001	1KGCM A	.001
1ATMA	.001	1BARVAC‡	.001	1KGCMVAC‡	.001
1ATMVAC‡	.001	±1BARG‡	.001	±1KGCMG‡	.001
±1ATMG‡	.001	1BARG	.001	1KGCMG	.001
1ATMG	.001	2BARA	.001	2KGCM A	.001
2ATMA	.001	2BARG	.001	2KGCMG	.001
2ATMG	.001	4BARG	.001	4KGCMG	.001
4ATMG	.001	7BARA	.001	7KGCM A	.001
7ATMA	.001	7BARG	.001	7KGCMG	.001
7ATMG	.001	-1V7BARG‡	.01	-1V7KGCMG‡	.01
-1V7ATMG‡	.01	14BARG	.01	14KGCMG	.01
14ATMG	.01	-1V14BARG‡	.01	-1V14KGCMG‡	.01
-1V14ATMG‡	.01	20BARG	.01	20KGCMG	.01
20ATMG	.01	35BARG	.01	35KGCMG	.01
34ATMG	.01	70BARG	.01	70KGCMG	.01
70ATMG	.01	140BARG	.1	140KGCMG	.1
140ATMG	.1	200BARG	.1	200KGCMG	.1
200ATMG	.1	350BARG	.1	350KGCMG	.1
340ATMG	.1				

**Display**

4 readings per second nominal display update rate  
 4 digit LCD, 0.5" H and 5 character 0.25" H alphanumeric  
**BL:** Red LED backlight on when gauge is on  
 Alarm 1 and Alarm 2 LCD indicators and bi-color (red/green) LEDs

**Controls & Functions**

**SEL** Select and display alarm trip points  
**TEST** Alarm acknowledge, or toggle alarms when in test mode  
 ▲ Increase alarm setpoint when in setpoint adjust mode  
 ▼ Decrease alarm setpoint when in setpoint adjust mode  
 Multi-level pass code protection for set-up and calibration

**ADA and DAR Alarm Outputs**

Programmable dual form C (SPDT) relay contacts for HI/LO, HI/HI, LO/LO, normal or reverse acting with 1% deadband, or adjustable trip and reset points for each relay, manual or auto acknowledge. 1A/24VDC, 0.5A/115VAC, non-inductive 120 milliseconds typical response time

**DAR Retransmission Output**

Updated approximately 16 times per second  
**-I:** Current output, 4-20 mA DC  
 Output drive (compliance) determined by power source  
 6,553 counts over sensor range  
**-V:** Voltage output, 0-2 VDC into 5k ohm or greater  
 6,553 counts over sensor range  
**-BV:** Bipolar voltage output (-2 - 0 - 2 V) for ±15 psig sensor only  
 ±2 VDC into 5k ohm or greater  
 13,107 counts over sensor range

**Calibration**

Non-interactive, ±10% of range  
 All pressure and absolute models: zero, midpoint, span  
 All vacuum models: -span, -midpoint, zero  
 Vacuum/pressure models: -span, zero, +midpoint, +span  
 ±15 psi models: -span, -midpoint, zero, +midpoint, +span

**Power**

8 to 24 VAC 50/60 Hz or 9 to 32 VDC  
 Gauge is on when power is on. Designed for continuous operation.  
 1.0 watt maximum power consumption

**Weight**

9.5 ounces (approx.), shipping wt. 1 pound (approx.)

**Housing**

**Standard:** Extruded aluminum case, epoxy powder coated, ABS/polycarbonate bezel, front and rear gaskets, polycarbonate label  
**N:** NEMA 4X ABS/polycarbonate case, rear gasket, polycarbonate label

**Connection, Material, Media Compatibility**

1/4" NPT male fitting, all wetted parts are 316L stainless steel

**Overpressure, Burst, Vacuum**

Ranges using 3000 psig sensor: 5000 psig  
 Ranges using 5000 psig sensor: 7500 psig  
 All others: 2 X pressure range  
 3000 psi, 5000 psi, and 4 digit ranges 112.5% full scale out-of-range display: 1--- or 1- ---  
 4 X sensor burst pressure rating, or 10,000 psi, whichever is less  
 Vacuum service: 15 psia, ±15 psig, 15 psig, 30 psia, 100 psig, 100 psia, 200 psig sensors

Under-range display (non-vacuum sensors): -Err

**Environmental**

Storage temperature: -40 to 203°F (-40 to 95°C)  
 Operating temperature: -4 to 185°F (-20 to 85°C)  
 Compensated temperature: 32 to 158°F (0 to 70°C)

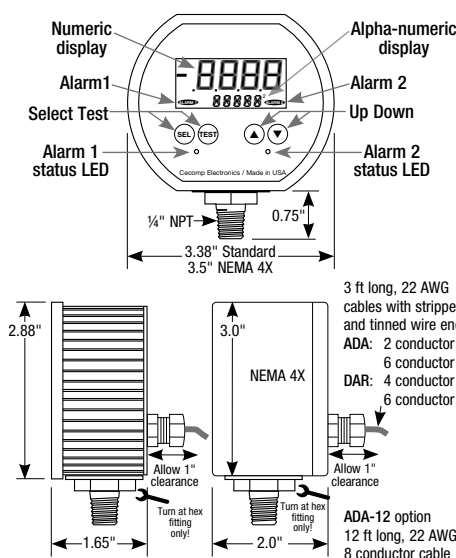

- ±0.25% Test Gauge Accuracy
- 316L Stainless Steel Wetted Parts
- ADA: Dual Programmable Alarms
- DAR: Dual Programmable Alarms and Output
- Low Voltage Powered



How to Specify	Type
F16ADA range - options	Dual alarms
F16ADABL range - options	Dual alarms, backlit display
F16ADAN range - options	Dual alarms, NEMA 4X
F16ADANBL range - options	Dual alarms, NEMA 4X, backlit display
F16DAR range - output - options	Dual alarms, analog output
F16DARBL range - output - options	Dual alarms, analog output, backlit display
F16DARN range - output - options	Dual alarms, analog output, NEMA 4X
F16DARNBL range - output - options	Dual alarms, analog output, NEMA 4X, backlit display

**Range**—see table at left  
 psi = PSI      torr = TORR      mbar = MBAR  
 inHg = INHG      mmH<sub>2</sub>O = MMH2O      bar = BAR  
 oz/in<sup>2</sup> = ZIN      kg/cm<sup>2</sup> = KGCM      cmH<sub>2</sub>O = CMH2O  
 inH<sub>2</sub>O = INH2O      g/cm<sup>2</sup> = GCM      atm = ATM  
 ftH<sub>2</sub>O = FTH2O      kPa = KPA  
 mmHg = MMHG      MPa = MPA  
 G = gauge reference pressure  
 VAC = gauge reference vacuum  
 A = absolute reference

**DAR Output**  
**I** 4-20 mA current output. Provides power to the loop.  
**V** 0-2 volt output  
**BV** ±2 volt output, for ranges using ±15 psig sensor only

**Options**—add to end of model number

HA	High accuracy, ±0.1% FS ±1 LSD. See table at left for availability.
PM	Panel mount, 4.1" x 4.1", n/a NEMA 4X
CC	Moisture resistant circuit board conformal coating
NC	NIST traceability documentation, 5 points and date

**Accessories**—order separately  
**WMPSK** Wall mount power supply kit, 115 VAC/12 VDC

**SCR14SS**  
 Filter screen fitting keeps debris out of gauge sensor. Use for food vacuum packaging applications. 303 SS body, 100 micron 304 SS screen.



## Installation Precautions

- ✓ Read these instructions before using the gauge. Configuration may be easier before installation. Contact the factory for assistance.
- ✓ These products do not contain user-serviceable parts. Contact us for repairs, service, or refurbishment.
- ✓ Gauges must be operated within specified ambient temperature ranges.
- ✓ Outdoor or wash down applications require a NEMA 4X gauge or installation in a NEMA 4X housing.
- ✓ Use a pressure or vacuum range appropriate for the application.
- ✓ Use fittings appropriate for the pressure range of the gauge.
- ✓ Due to the hardness of 316 stainless steel, it is recommended that a thread sealant be used to ensure leak-free operation.
- ✓ For contaminated media use an appropriate screen or filter to keep debris out of gauge port.
- ✓ Remove system pressures before removing or installing gauge.
- ✓ Install or remove gauge using a wrench on the hex fitting only. Do not attempt to turn gauge by forcing the housing.
- ✓ Do not exceed relay current and voltage ratings. Use an appropriate contactor for larger loads. Inductive inrush currents may be up to 5x normal current and may require an RC snubber.
- ✓ Good design practice dictates that positive displacement liquid pumps include protection devices to prevent sensor damage from pressure spikes, acceleration head, and vacuum extremes.
- ✗ Avoid permanent sensor damage! Do not apply vacuum to non-vacuum gauges or hydraulic vacuum to any gauges.
- ✗ Avoid permanent sensor damage! NEVER insert objects into gauge port or blow out with compressed air.
- ⚠ Gauges are not for oxygen service. Accidental rupture of sensor diaphragm may cause silicone oil inside sensor to react with oxygen.
- ✗ NEVER connect the gauge power wires directly to 115 VAC or permanent damage will result.

## Types of Gauges

Gauge reference models read zero with the gauge port open. Bipolar ranges read positive pressure and vacuum in the same units, and zero with the gauge port open. 1000 psi and higher sensors are a sealed reference type. They read zero with the gauge port open are internally referenced to 14.7 psi. They are functionally similar to gauge reference sensors. Absolute reference gauges read zero at full vacuum and atmospheric pressure with the gauge port open. Atmospheric pressure varies continuously.

## Electrical Connections

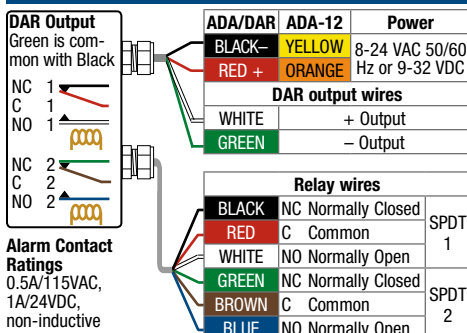

The ADA 2-conductor cable or the DAR 4-conductor cable with the RED and BLACK leads is for the gauge power supply. ADA models with the 12 foot lead option use an 8 conductor cable with YELLOW and ORANGE power leads.

Use correct DC polarity on DAR models. Either polarity may be used for AC power. Note that 24 VAC transformers with small loads often operate over the 24 VAC limit. The supply voltage, when within the stated ranges, has negligible effect on the gauge calibration. Operation below 9 VDC or 8 VAC may cause erratic or erroneous readings or output.

When operating multiple gauges from the same power supply, refer to the mA rating in the specifications to ensure adequate power. Route the wires away from heat sources and moving equipment.

## Contact Rating and Protection

The alarm contacts are rated at 1A/24VDC or 0.5A/115VAC. Using mechanical relay contacts above their rating, or with large inductive loads, will shorten their life. For inductive loads, RC snubbers or arc suppression devices are required to protect the contacts. For large loads a higher capacity contactor is required.

No internal fusing is included in the alarm contact circuits. The alarm outputs should be externally fused by the user in applications where good design practice dictates.

## Power Up

The gauge is powered on whenever a supply voltage is applied. Warm-up time is negligible. The gauge may be left on at all times. All configuration information is stored in non-volatile memory.

When power is first applied, the gauge proceeds through a startup sequence. During the startup sequence, relays are de-energized, the status LEDs are off, and the retransmission output is low (-2.5 VDC or 0 mA).

1. The firmware version number is displayed briefly
2. All active display segments are turned on for approx. 1 second.
3. The full scale pressure is indicated for approx. 1 second while the engineering units and FS (full scale) are indicated for 1/2 second on the character display.
4. The display is tested again for approximately 1 second.

The gauge then proceeds to the normal operating mode.

For DAR models the retransmission output corresponds to the applied pressure.

## Alarm Types

The factory default configuration is 1% fixed deadband mode with SP1 HI and SP2 LO, normal acting relays, zero tare enabled, and no pass code required for test function.

Alarms may be configured to operate in fixed deadband mode or adjustable hysteresis mode.

In the fixed deadband mode, the alarm set/reset point deadband is factory set to 1% of full-scale. Each alarm may be configured as either HI or LO with a user adjustable alarm set point for each relay.

In the adjustable hysteresis mode, two independent set and reset trip points are user adjustable for each relay. The set or reset state at power up when between trip points is user configurable.

## Operation with Fixed Deadband Alarms

Each relay may be independently configured as a high or low alarm in User Set-up and operate as shown in the table below.

Normal acting, High alarm SP_H		
Pressure	< Set point - 1%FS	> Set point
Relay coil	On	Off
Alarm 1 continuity	C-NO (Red-White)	C-NC (Red-Black)
Alarm 2 continuity	C-NO (Brown-Blue)	C-NC (Brown-Green)
LED	Green	Red

Normal acting, Low alarm SP_L		
Pressure	< Set point	> Set point + 1%FS
Relay coil	Off	On
Alarm 1 continuity	C-NC (Red-Black)	C-NO (Red-White)
Alarm 2 continuity	C-NC (Brown-Green)	C-NO (Brown-Blue)
LED	Red	Green

Reverse acting, High alarm SP_H		
Pressure	< Set point - 1%FS	> Set point
Relay coil	Off	On
Alarm 1 continuity	C-NC (Red-Black)	C-NO (Red-White)
Alarm 2 continuity	C-NC (Brown-Green)	C-NO (Brown-Blue)
LED	Green	Red

Reverse acting, Low alarm SP_L		
Pressure	< Set point	> Set point + 1%FS
Relay coil	On	Off
Alarm 1 continuity	C-NO (Red-White)	C-NC (Red-Black)
Alarm 2 continuity	C-NO (Brown-Blue)	C-NC (Brown-Green)
LED	Red	Green

The relevant LCD alarm icon will indicate an alarm condition.

The relevant bi-color LED will be illuminated green for a normal condition or red for an alarm condition.

The LED will blink at a slow rate until the alarm is acknowledged unless the annunciator mode was disabled in set-up.

Alarms may be configured to be automatically acknowledged when the alarm condition clears or configured to be manually acknowledged by pressing the TEST button.

The applied pressure, the value of Trip Point 1, and the value of Trip Point 2 may be selected for display as follows:

When the applied pressure is being displayed, press and release the SEL button. The Trip Point 1 value will be displayed with TRIP1 on the lower display.

When the Trip Point 1 value is being displayed, press and release the SEL button. The upper display will indicate the Trip Point 2 value with TRIP2 on the lower display.

When the Trip Point 2 value is being displayed, press and release the SEL button. The upper display will indicate the applied pressure with engineering units on the lower display.

## Operation with Adjustable Hysteresis Alarms

In the adjustable hysteresis mode, two independent set and reset trip points used for each relay. The LEDs indicate green for a RESET state and red for a SET state. Refer to the table below.

Normal (Fail-safe) acting, RESET value less than SET		
Pressure	≤ Low RESET point	≥ High SET point
Relay coil	On	Off
Alarm 1 continuity	C-NO (Red-White)	C-NC (Red-Black)
Alarm 2 continuity	C-NO (Brown-Blue)	C-NC (Brown-Green)
LED	Green	Red

Normal (Fail-safe) acting, SET value less than RESET		
Pressure	≤ Low SET point	≥ High RESET point
Relay coil	Off	On
Alarm 1 continuity	C-NC (Red-Black)	C-NO (Red-White)
Alarm 2 continuity	C-NC (Brown-Green)	C-NO (Brown-Blue)
LED	Red	Green

Reverse acting, RESET value less than SET		
Pressure	≤ Low RESET point	≥ High SET point
Relay coil	Off	On
Alarm 1 continuity	C-NC (Red-Black)	C-NO (Red-White)
Alarm 2 continuity	C-NC (Brown-Green)	C-NO (Brown-Blue)
LED	Green	Red

Reverse acting, SET value less than RESET		
Pressure	≤ Low SET point	≥ High RESET point
Relay coil	On	Off
Alarm 1 continuity	C-NO (Red-White)	C-NC (Red-Black)
Alarm 2 continuity	C-NO (Brown-Blue)	C-NC (Brown-Green)
LED	Red	Green

Power-up relay state when between SET and RESET		
Config. set to SP_L		RESET
Config. set to SP_H		SET

If the gauge is configured for alarms, ALARM1 and ALARM2 will be indicated when alarm conditions exist, and the associated LEDs will blink to indicate unacknowledged alarm conditions. Alarms may be configured to be automatically acknowledged when the alarm condition clears or manually acknowledged by pressing the TEST button.

The SET trip points, and the RESET trip points may be selected for display as follows.

While in the normal operating mode, press and release the SEL button. The upper display will indicate the value of set point 1 with 'SET\_1' on the lower display.

While set point 1 is being displayed, press and release the SEL button. The upper display will indicate the value of reset point 1 with 'RST\_1' on the lower display.

While reset point 1 is being displayed, press and release the SEL button. The upper display will indicate the value of set point 2 with 'SET\_2' on the lower display.

While set point 2 is being displayed, press and release the SEL button. The upper display will indicate the value of reset point 2 with 'RST\_2' on the lower display.

While the reset point 2 is being displayed, press and release the SEL button. The upper display will indicate the applied pressure and engineering units.

## F16DAR Output Types

DAR model retransmission output corresponds to the applied pressure, except when in zero/tare mode, test mode, or during setup. Note that analog output resolution is always over the entire sensor range and is updated approximately 16 times per second. The -I version 4-20 mA output provides power to the current loop and output drive is determined by power source.

Output values listed below are nominal factory set ranges and may be user reconfigured. Note that -15 psi, -100 kPa, etc. is not achievable, but prevents running out of range at whatever full vacuum is reached.

Range Type	Output Option	-15 psi	"0" on display	Full pressure
Gauge reference pressure	-I	n/a	4 mA	20 mA
	-V	n/a	0 V	2 V
Gauge reference vacuum	-I	20 mA	4 mA	n/a
	-V	2 V	0 V	n/a
Absolute reference	-I	4 mA	4 mA	20 mA
	-V	0 V	0 V	2 V
Vacuum/pressure ranges using ±15 psi sensor	-I	4 mA	12 mA	20 mA
	-V	0 V	1 V	2 V
Vacuum/pressure ranges using -15/100 psi	-BV	-2 V	0 V	2 V
	-I	4 mA	~6.1 mA	20 mA
Vacuum/pressure ranges using -15V/200 psi	-V	0 V	~0.26 V	2 V
	-I	4 mA	~5.1 mA	20 mA
Vacuum/pressure ranges using -15V/200 psi	-V	0 V	~0.14 V	2 V



**Pass Code Entry**

A pass code is required to calibrate and configure the gauge. Additional levels of security may be enabled by defining separate pass codes for calibration, user configuration, and output test and set point adjust modes. See Changing the User-Defined Pass Code at the end of this manual to change pass codes.

Functions in user configuration mode

- Restore original factory configuration
- Enable/disable zero tare function
- Fixed 1% deadband or adjustable hysteresis mode of operation
- Operation for blinking alarm LEDs
- Set point modes (high alarm/low alarm or state at power-up)
- Relay action mode (normal/reverse)
- DAR model retransmission output upper and lower limits
- Enable/disable a pass code for output test and set point adjust

When the gauge enters a mode requiring a pass code, the display indicates `_____` with the first underscore blinking, and either TSTPC, CFGPC, CALPC on the lower display. All three pass codes are initially set to the factory default of 3510.

Note: During pass code entry the LEDs will be off and the gauge will not respond to changes in applied pressure. The relays will maintain their prior state. The gauge will automatically revert to the normal operation if no buttons are operated for approximately 15 seconds.

Use the ▲ and ▼ buttons to set the left-most digit to 3.

Press and release the SEL button to index to the next position. The 3 will remain, and the second position will be blinking.

Use the ▲ and ▼ buttons to select 5.

Press and release the SEL button to index to the next position. 3 5 will remain, and the third position will be blinking.

Use the ▲ and ▼ buttons to select 1.

Press and release the SEL button to index to the next position. 3 5 1 will remain, and the fourth position will be blinking.

Use the ▲ and ▼ buttons to select 0.

Press and release the SEL button to proceed.

If an incorrect pass code was entered, the gauge will exit to the normal operating mode. Upon successful pass code entry, follow the steps in the appropriate section of this manual.

Note: To exit a mode at any time, press and hold the SEL button until the display indicates `_____`.

**Zero Tare Mode**

If the gauge is not indicating zero with zero pressure applied but is within approximately 3% of full scale pressure of zero, you may tare the gauge to zero. This feature may be enabled or disabled. Absolute ranges are configured with this feature turned off.

From the normal operating mode with the gauge port open to atmosphere, press and hold both the ▲ and ▼ buttons and press the SEL button. The relay outputs and the retransmission output will hold the last value, and the visual indicators will be deactivated. Release all buttons when the display indicates `o o o o`.

The display will indicate a newly calculated zero tare value with Z OFF on the lower display. Note: If not within approximately 3% of zero, Err0 will be displayed. Press the SEL button to cancel the operation and return to normal operating mode without affecting any existing zero tare value.

To cancel and remove any existing zero tare value, press and release the ▼ button. The display will indicate zero. To restore the newly calculated zero tare value, press and release the ▲ button.

To exit the Zero/Tare mode, press and release the SEL button. The gauge will return to normal operation.

**Output Test Mode**

From the normal operating mode, press and hold the TEST button and press the SEL button. Release both buttons when the display indicates `_____` or `_____`.

If pass code protection is enabled, the display indicates `_____` with the left-most underscore blinking, and TSTPC.

Enter the pass code as described in the Pass Code Entry section.

While in the Test mode with no buttons pressed, the display will indicate the pressure with the engineering units blinking at a slow rate.

When the TEST button is pressed, the LED indicators and the relays will toggle to their opposite states. The display will indicate the preset test value with TEST on the lower display, and the retransmission output on DAR models will correspond to the test value.

Pressing the ▲ or the ▼ button while holding the TEST button will raise or lower the test value. Note that the gauge will not respond to changes in applied pressure while the TEST button is held.

When the TEST button is released, the display, the LED indicators, and the relay outputs will correspond to the applied pressure.

Press and release the SEL button to exit the Output Test mode and return to normal operation.

**Adjust Setpoint, Fixed Deadband Mode**

“Set Point” is defined as the pressure value that will result in a change of state only from a normal to an alarm condition.

“Trip Point” is defined as the pressure value that will result in a change of state of alarm condition, and includes the effect of deadband when returning from an alarm to a normal condition.

**Set Point 1**

From the normal operating mode press the SEL button to display Trip Point 1.

Press and hold the TEST button and press the SEL button. Release both buttons when the display indicates `_____`.

If pass code protection is enabled, before the unit enters the Set Point 1 Adjust Mode, the display initially indicates `_____` with the left-most underscore blinking, and with TSTPC on the display.

Enter the pass code as described in the Pass Code Entry section.

While in the Set Point 1 Adjust mode with no buttons pressed, the display will indicate Trip Point 1 with TRIP1 blinking at a slow rate on the lower display, and the alarm indicators and the retransmission output will correspond to the applied pressure.

To adjust the Set Point 1 value, press and hold the TEST button. The display will indicate Set Point 1 with SP1 on the lower display.

Operate the ▲ and ▼ buttons to adjust Set Point 1 to the desired value. Release the TEST button to store the Set Point 1 value.

Note: The gauge will not respond to changes in applied pressure while the TEST button is pressed. The alarm relays, LEDs, LCD alarm icons, and the DAR output will maintain their prior states until the TEST button is released.

To exit the Set Point 1 Adjust mode and return to the normal operating mode, press and release the SEL button.

**Set Point 2**

From the normal operating mode press the SEL button twice to display Trip Point 2.

Press and hold the TEST button and press the SEL button. Release both buttons when the display indicates `_____`.

If pass code protection is enabled, before the unit enters the Set Point 2 Adjust Mode, the display initially indicates `_____` with the left-most underscore blinking, and with TSTPC on the display.

Enter the pass code as described in the Pass Code Entry section.

While in the Set Point 2 Adjust mode with no buttons pressed, the display will indicate Trip Point 2 with TRIP2 blinking at a slow rate on the lower display, and the alarm indicators and the retransmission output will correspond to the applied pressure.

To adjust the Set Point 2 value, press and hold the TEST button. The display will indicate Set Point 2 with SP2 on the lower display.

Operate the ▲ and ▼ buttons to adjust Set Point 2 to the desired value. Release the TEST button to store the Set Point 2 value.

Note: The gauge will not respond to changes in applied pressure while the TEST button is pressed. The alarm relays, LEDs, LCD alarm icons, and the DAR output will maintain their prior states until the TEST button is released.

To exit the Set Point 2 Adjust mode and return to normal operation, press and release the SEL button.

**Adjust Trip Point, Adjustable Hysteresis Mode**

From the normal operating mode press the SEL button to display the desired trip point (SET\_1, RST\_1, SET\_2, or RST\_2).

Press and hold the TEST button and press the SEL button. Release both buttons when the display indicates `_____`.

If pass code protection is enabled, before the unit enters the Set Point Adjust Mode, the display initially indicates `_____` with the left-most underscore blinking, and with TSTPC on the lower display.

Enter the pass code as described in the Pass Code Entry section.

While in the Trip Point Adjust mode with no buttons pressed, the display will indicate the trip point value with its designator (SET\_1, RST\_1, SET\_2, or RST\_2) blinking at a slow rate.

To adjust the displayed trip point value, press and hold the TEST button. The display will continue to indicate the trip point value.

Operate the ▲ and ▼ buttons to adjust the trip point to the desired value. The trip point value is stored when the TEST button is released. Note: The relays and indicators will not correspond to the applied pressure value until the TEST button is released.

To exit the Trip Point Adjust mode and return to the normal operating mode, press and release the SEL button.

**User Configuration**

From the normal operating mode, press and hold the TEST and the ▲ buttons.

Then press the SEL button.

Release all buttons when the display indicates CFG.

Before the gauge enters the Configuration mode, the display initially

**User Configuration—cont.**

indicates `_____` with the first underscore blinking, and with CFGPC on the lower display.

Enter the pass code as described in the Pass Code Entry section.

**Restore Factory Configuration**

The upper display will be blank, and the lower display will display either USER\_ or FCTRY.

If USER\_ is selected, the existing user configuration will be retained and will be accessible for modification in the following steps. To select USER\_, press and release the ▼ button. The lower display will indicate USER\_.

If FCTRY is selected, the existing user configuration will be replaced by the configuration as it left the factory and will be accessible for modification in the following steps. To select FCTRY, press and release the ▲ button. The lower display will indicate FCTRY.

Press and release the SEL button to move on to the next parameter.

**Zero Tare Configuration**

The upper display will be blank, and the lower display will indicate either ZTARE or NOZTR.

If ZTARE is selected, the user will be able to manually zero the gauge from the normal operating mode.

To select ZTARE, press and release the ▲ button. The lower display will indicate ZTARE.

If NOZTR is selected the user will be prevented from zeroing the gauge from the normal operating mode. This is default setting for absolute reference ranges.

To select NOZTR, press and release the ▼ button. The lower display will indicate NOZTR.

Press and release the SEL button to move on to the next parameter.

**Setpoint Type Configuration**

The lower display will either indicate DBAND or ADJ\_H.

If DBAND is selected, each output relay will operate with a 1% of full-scale deadband between set and reset.

To select DBAND, press and release the ▲ button. The lower display will indicate DBAND.

If ADJ\_H is selected, each output relay will have an adjustable SET point and an adjustable RESET point.

To select ADJ\_H, press and release the ▼ button. The lower display will indicate ADJ\_H.

Press and release the SEL button to move on to the next parameter.

**Alarm Annunciator Function Selection**

The lower display will indicate either A\_ACK, M\_ACK or NO\_AN.

If A\_ACK is selected, an alarm condition will be automatically acknowledged when the alarm condition clears. When an alarm condition occurs, the LED for that alarm will begin to blink red and will continue to blink red until it has been manually acknowledged or until the alarm condition clears. If an alarm is manually acknowledged, the LED will be steadily red while the alarm condition continues to exist. The LED will be steadily green whenever no alarm condition exists.

If M\_ACK is selected, an alarm condition must be manually acknowledged. When an alarm condition occurs, the LED for that alarm will blink red if the alarm condition exists or green if the alarm condition no longer exists. The LED will continue to blink until it has been manually acknowledged by a pressing the TEST button. Once an alarm has been acknowledged, the LED will be steadily red while the alarm condition exists or green when the alarm no longer exists.

If NO\_AN is selected, the LEDs will not blink. When an alarm condition occurs, the LED associated with that alarm will be illuminated steadily red if the alarm condition exists or green if the alarm condition no longer exists. In addition, the LCD display for ALARM1 and ALARM2 will not be displayed during alarm conditions.

Use the ▲ or ▼ buttons to cycle through the three choices. When the lower display indicates the desired annunciator action, press and release the SEL button to move on to the next parameter.

**Alarm Action Selection (Fixed Deadband Configuration)**

The lower display will display either SP1\_L or SP1\_H.

If SP1\_L is selected Alarm 1 will be a low alarm. Alarm 1 will be SET when the pressure falls below Setpoint 1. Alarm 1 will be RESET when the pressure rises above Setpoint 1 plus the preset deadband. To select SP1\_L, press and release the ▼ button. The lower display will indicate SP1\_L.

If SP1\_H is selected Alarm 1 will be a high alarm. Alarm 1 will be SET when the pressure rises above Setpoint 1. Alarm 1 will be RESET when the pressure falls below Setpoint 1 minus the preset deadband. To select SP1\_H, press and release the ▲ button. The lower display will indicate SP1\_H.

Press and release the SEL button to move to Alarm 2.

The upper display will be blank, and the lower display will display either SP2\_L or SP2\_H.

If SP2\_L is selected Alarm 2 will be a low alarm. Alarm 2 will be SET



### User Configuration—cont.

when the pressure falls below Setpoint 2. Alarm 2 will be RESET when the pressure rises above Setpoint 2 plus the preset deadband. To select SP2\_L, press and release the ▼ button. The lower display will indicate SP2\_L.

If SP2\_H is selected Alarm 2 will be a high alarm. Alarm 2 will be SET when the pressure rises above Setpoint 2. Alarm 2 will be RESET when the pressure falls below Setpoint 2 minus the preset deadband. To select SP2\_H, press and release the ▲ button. The lower display will indicate SP2\_H.

Press and release the SEL button to move to the next parameter.

#### Relay Action Selection (Fixed Deadband Configuration)

The lower display will display either \_NOR\_ or \_REV\_.

If \_NOR\_ is selected, the output relay coils will be energized in the RESET state and de-energized in the SET state (normal action). To select \_NOR\_, press and release the ▼ button. The lower display will indicate \_NOR\_.

If \_REV\_ is selected, the output relay coils will be de-energized in the RESET state and energized in the SET state (reverse action). To select \_REV\_, press and release the ▲ button. The lower display will indicate \_REV\_.

Press and release the SEL button to move on to the next parameter.

#### Relay Power Up State (Adjustable Hysteresis Configuration)

The lower display will display either SP1\_L or SP1\_H.

If SP1\_L is selected and the gauge is powered up while the applied pressure is between the Output 1 SET and RESET trip points, Output 1 will begin in the RESET state. To select SP1\_L, press and release the ▼ button. The lower display will indicate SP1\_L.

If SP1\_H is selected and the gauge is powered up while the applied pressure is between the Output 1 SET and RESET trip points, Output 1 will begin in the SET state. To select SP1\_H, press and release the ▲ button. The lower display will indicate SP1\_H.

Press and release the SEL button to move to Relay 2.

The upper display will be blank, and the lower display will display either SP2\_L or SP2\_H.

If SP2\_L is selected and the gauge is powered up while the applied pressure is between the Output 2 SET and RESET trip points, Output 2 will begin in the RESET state. To select SP2\_L, press and release the ▼ button. The lower display will indicate SP2\_L.

If SP2\_H is selected and the gauge is powered up while the applied pressure is between the Output 2 SET and RESET trip points, Output 2 will begin in the SET state. To select SP2\_H, press and release the ▲ button. The lower display will indicate SP2\_H.

Press and release the SEL button to move on to the next parameter.

#### Relay Action Selection (Adjustable Hysteresis Configuration)

The upper display will be blank, and the lower display will display either \_NOR1\_ or \_REV1\_.

If \_NOR1\_ is selected, the Output 1 relay coil will be energized in the RESET state and de-energized in the SET state (normal action). To select \_NOR1\_, press and release the ▼ button. The lower display will indicate \_NOR1\_.

If \_REV1\_ is selected, the Output 1 relay coil will be de-energized in the RESET state and energized in the SET state (reverse action). To select \_REV1\_, press and release the ▲ button. The lower display will indicate \_REV1\_.

Press and release the SEL button to move on to Relay 2.

The upper display will be blank, and the lower display will display either \_NOR2\_ or \_REV2\_.

If \_NOR2\_ is selected, the Output 2 relay coil will be energized in the RESET state and de-energized in the SET state (normal action). To select \_NOR2\_, press and release the ▼ button. The lower display will indicate \_NOR2\_.

If \_REV2\_ is selected, the Output 2 relay coil will be de-energized in the RESET state and energized in the SET state (reverse action). To select \_REV2\_, press and release the ▲ button. The lower display will indicate \_REV2\_.

Press and release the SEL button to move on to the next parameter.

#### Analog Output Range Lower Limit Adjust (DAR only)

The upper display will indicate the pressure value corresponding to the minimum retransmission output, either 4 mA, 0 VDC, or –2 VDC depending on the particular gauge model. The lower display will display RNLGLO.

Use the ▲ and ▼ buttons to adjust the display to the desired value.

Press and release the SEL button to move on to the next parameter.

#### Analog Output Range Upper Limit Adjust (DAR only)

The upper display will indicate the pressure value corresponding to the maximum retransmission output, either 4 mA or +2 VDC depending on the particular gauge model. The lower display will display RNGHI.

Use the ▲ and ▼ buttons to adjust the display to the desired value.

### User Configuration—cont.

Press and release the SEL button to move to the next parameter.

#### Output Test and Set Point Adjust Modes Pass Code Protection

The upper display section will be blank, and the lower section will display either TSTPC or NOTPC.

To enable Output Test and Set Point Adjust Modes pass code protection, press and release the ▲ button. The lower display will indicate TSTPC.

To disable Output Test and Set Point Adjust Modes pass code protection, press and release the ▼ button. The lower display will indicate NOTPC.

Press and release the SEL button to save the configuration parameters and restart the unit. Note: The configuration parameters will not be saved if the procedure is interrupted before completion.

### Calibration Preparation

The gauge is calibrated at the factory using equipment traceable to NIST. There is no need to calibrate the gauge before putting it in service. Calibration should only be performed by qualified individuals using appropriate calibration standards and procedures.

The calibration equipment should be at least four times more accurate than the gauge being calibrated. The calibration system must be able to generate and measure pressure/vacuum over the full range of the gauge. A vacuum pump able to produce a vacuum of 100 microns (0.1 torr or 100 millitorr) or lower is required for vacuum and absolute gauges.

For DAR models use an accurate volt or mA meter for calibration of the retransmission output.

Allow the gauge to equalize to normal room temperature (about 20 minutes minimum) before calibration.

### Calibration

To enter the calibration mode from the normal operating mode with applied pressure being displayed, press and hold the TEST and the ▼ buttons. Then press the SEL button. Release all buttons when the display indicates CAL.

When the gauge enters the calibration mode, the display initially indicates \_ \_ \_ \_ with the first underscore blinking, and with CALPC on the lower display.

Enter the pass code as described in the Pass Code Entry section.

Upon successful calibration pass code entry, the upper display will indicate the applied pressure in the configured engineering units.

The lower display of the display will alternate between CAL and the calibration region corresponding to the applied pressure (ZERO, +MID, +SPAN, MID, or SPAN).

Note: To store the calibration parameters and exit calibration mode at any time, press and hold the SEL button until the display indicates \_ \_ \_ \_ .

#### Calibration of the Retransmission Output (DAR only)

Calibration of the retransmission output coordinates the retransmission output to the display indication, and is performed independently of applied pressure. It requires a direct physical measurement of the retransmission output.

#### Retransmission Output Low Value (DAR only)

Press and release the SEL button to step to the retransmission output low value calibration sequence, indicated by LCAL on the display.

Note: If the SEL button is held depressed for longer than 2 seconds, the display will change to indicate \_ \_ \_ \_ , and the gauge will exit the calibration mode when all buttons are released.

The upper display will indicate the pre-configured pressure corresponding to the retransmission output low value. The lower display will alternate between CAL and 4 mA, 0 VDC, or –2 VDC depending on retransmission option.

Use the ▲ and ▼ buttons to adjust the actual retransmission output to its low value.

#### Retransmission Output High Value (DAR only)

Press and release the SEL button to step to the retransmission output high value calibration sequence, indicated by HCAL on the display.

Note: If the SEL button is held depressed for longer than 2 seconds, the display will change to indicate \_ \_ \_ \_ , and the gauge will exit the calibration mode when all buttons are released.

The upper display will indicate the pre-configured pressure corresponding to the retransmission output high value. The lower display will alternate between CAL and 20 mA or +2 VDC depending on retransmission option.

Use the ▲ and ▼ buttons to adjust the actual retransmission output to its high value.

#### Pressure Calibration

The pressure calibration procedure adjusts the display indication, and for DAR models also the retransmission output, to correspond to the actual applied pressure.

### Calibration—cont.

If the applied pressure is not being displayed, press and release the SEL button to step to the pressure calibration sequence, indicated by CAL on the display.

Note: If the SEL button is held depressed for longer than 2 seconds, the display will change to indicate \_ \_ \_ \_ , and the gauge will exit the calibration mode when all buttons are released.

**Zero calibration:** Apply zero pressure. The lower display will alternate between CAL and ZERO. Use the ▲ and ▼ buttons to adjust the upper display to indicate zero.

**Span calibration:** Apply full-scale pressure. The lower display will alternate between CAL and +SPAN. Use the ▲ and ▼ buttons to adjust the upper display to indicate the applied pressure value.

**Midpoint Non-Linearity calibration:** Apply 50% full-scale positive pressure. The lower display will alternate between CAL and +MID. Use the ▲ and ▼ buttons to adjust the upper display to indicate the applied pressure value.

**Negative Span calibration (bipolar and compound ranges only):** Apply full-scale negative pressure. The lower display will alternate between CAL and SPAN. Use the ▲ and ▼ buttons to adjust the upper display to indicate the applied pressure value.

**Negative Midpoint Non-Linearity calibration (bipolar ranges only):** Apply 50% full-scale negative pressure. The lower display will alternate between CAL and MID. Use the ▲ and ▼ buttons to adjust the upper display to indicate the applied pressure value.

To store the calibration parameters and exit calibration mode, press and hold the SEL button until the display indicates \_ \_ \_ \_ .

### Changing the User-Defined Pass Codes

#### Configuration Pass Code

From the normal operating mode, press and hold the TEST and the ▲ buttons. Then press the SEL button. Release all buttons when the display indicates CFG.

#### Calibration Pass Code

From the normal operating mode, press and hold the TEST and the ▼ buttons. Then press the SEL button. Release all buttons when the display indicates CAL.

#### Test and Set Point Adjust Pass Code (optional)

From the normal operating mode, press and hold the TEST button. Then press the SEL button. Release all buttons when the display indicates \_ \_ \_ \_ .

Before the unit enters the view or change pass code mode, the display initially indicates \_ \_ \_ \_ with the first underscore blinking, and with CFGPC, CALPC, or TSTPC on the lower display.

Note: during pass code entry, the LEDs will be off and the gauge will not respond to changes in applied pressure. The output relays will maintain their prior states and the retransmission output will maintain its prior value. The gauge will automatically revert to normal operation if no buttons are operated for approximately 15 seconds.

#### Enter Factory Pass Code 1220

Use the ▲ and ▼ buttons to set the left-most digit to 1.

Press and release the SEL button to index to the next position. The 1 will remain, and the second position will be blinking.

Use the ▲ and ▼ buttons to select 2.

Press and release the SEL button to index to the next position. 1 2 will remain, and the third position will be blinking.

Use the ▲ and ▼ buttons to select 2.

Press and release the SEL button to index to the next position. 1 2 2 will remain, and the fourth position will be blinking.

Use the ▲ and ▼ buttons to select 0.

Press and release the SEL button to proceed. Note: If an incorrect pass code was entered, the gauge will exit to the normal operating mode.

Once the correct password has been entered, the display will indicate the existing pass code with CFGPC, CALPC, or TSTPC on the character segments.

Note: while in the pass code change mode, the LEDs will extinguish and the unit will not respond to changes in applied pressure and the output relays will be de-energized.

Operate the ▲ or ▼ button to select the first character of the calibration password.

When the correct first character is being displayed, press and release the SEL button to proceed to the next password character. Repeat 1 & 2 above until the entire password is complete.

To exit the User-Defined Pass Code change mode, press and hold the SEL button. Release the button when the display indicates \_ \_ \_ \_ and restarts in the normal operating mode.

CECOMP maintains a constant effort to upgrade and improve its products. Specifications are subject to change without notice. Consult factory for your specific requirements.